

deli

DE-XQ355-1E

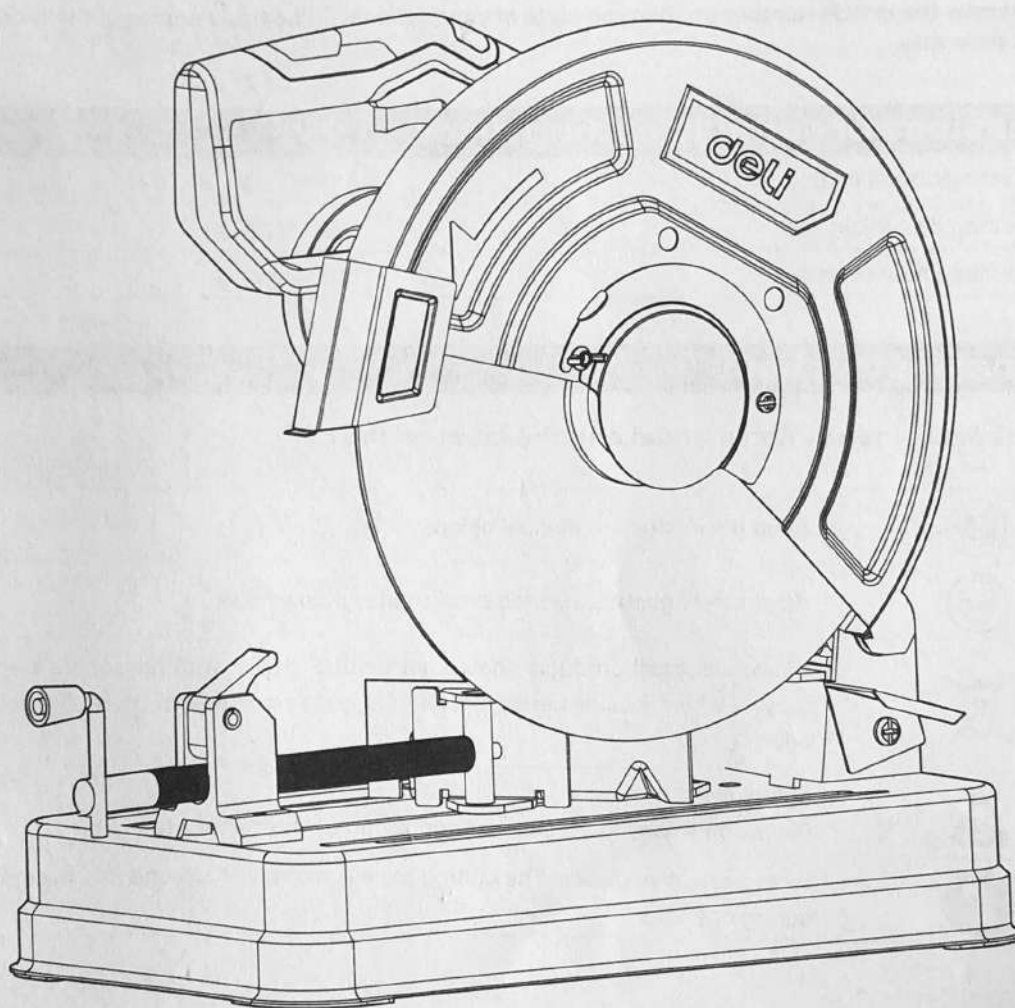

EN Cut off saw
DE Profilschneidemaschine
FR Découpeur de profilé
ES Sierra de corte

PT Serra de corte
RU Монтажная пила
AR آلة قطع

Cut off saw

Article number	DE-XQ355-1E
Rated power input	2350W
Rated voltage	220-240V~
Frequency	50/60Hz
No-load speed	3800/min
Machine weight	17kg

Accessories

- Wrench
- Carbon brush
- Cutting disc





Please observe the article number on the type plate of your machine. The trade names of the individual machines may vary.

Dimensions of suitable cutting discs

Cutting disc diameter	355mm(14")
Cutting disc thickness	3mm(1/8")
Mounting hole diameter	25.4mm(1")

Original Instructions

The symbols in instruction manual and the label on the tool

	Read the instruction manual before using.
	Wear safety glasses, hearing protection and dust mask.
	Waste electrical products should not be disposed of with household waste. Please recycle where facilities exist. Check with your Local Authority or retailer for recycling advice.
	Safety alert. Please only use the accessories supported by the manufacturer.
	Wear protective gloves. The cutting blades are very sharp and can become very hot during operation.

General Power Tool Safety Warnings

WARNING

Read all safety warnings, instructions, illustrations and specifications provided with this power tool. Failure to follow all instructions listed below may result in electric shock, fire and/or serious injury. Save all warnings and instructions for future reference.

The term "power tool" in the warnings refers to your mains-operated (corded) power tool or battery-operated (cordless) power tool.

Work area safety

1. **Keep work area clean and well lit.** Cluttered or dark areas invite accidents.
2. **Do not operate power tools in explosive atmospheres, such as in the presence of flammable liquids, gases or dust.** Power tools create sparks which may ignite the dust or fumes.
3. **Keep children and bystanders away while operating a power tool.** Distractions can cause you to lose control

Electrical safety

1. **Power tool plugs must match the outlet. Never modify the plug in any way. Do not use any adapter plugs with earthed (grounded) power tools.** Unmodified plugs and matching outlets will reduce risk of electric shock.
2. **Avoid body contact with earthed or grounded surfaces, such as pipes, radiators, ranges and refrigerators.** There is an increased risk of electric shock if your body is earthed or grounded.
3. **Do not expose power tools to rain or wet conditions.** Water entering a power tool will increase the risk of electric shock.
4. **Do not abuse the cord. Never use the cord for carrying, pulling or unplugging the power tool. Keep cord away from heat, oil, sharp edges or moving parts.** Damaged or entangled cords increase the risk of electric shock.
5. **When operating a power tool outdoors, use an extension cord suitable for outdoor use.** Use of a cord suitable for outdoor use reduces the risk of electric shock.
6. **If operating a power tool in a damp location is unavoidable, use a residual**

current device (RCD) protected supply. Use of an RCD reduces the risk of electric shock.

Personal safety

1. **Stay alert, watch what you are doing and use common sense when operating a power tool. Do not use a power tool while you are tired or under the influence of drugs, alcohol or medication.** A moment of inattention while operating power tools may result in serious personal injury.
2. **Use personal protective equipment. Always wear eye protection.** Protective equipment such as a dust mask, non-skid safety shoes, hard hat or hearing protection used for appropriate conditions will reduce personal injuries.
3. **Prevent unintentional starting. Ensure the switch is in the off- position before connecting to power source and/or battery pack, picking up or carrying the tool.** Carrying power tools with your finger on the switch or energising power tools that have the switch on invites accidents.
4. **Remove any adjusting key or wrench before turning the power tool on.** A wrench or a key left attached to a rotating part of the power tool may result in personal injury.
5. **Do not overreach. Keep proper footing and balance at all times.** This enables better control of the power tool in unexpected situations.
6. **Dress properly. Do not wear loose clothing or jewellery. Keep your hair and clothing away from moving parts.** Loose clothes, jewellery or long hair can be caught in moving parts.
7. **If devices are provided for the connection of dust extraction and collection facilities, ensure these are connected and properly used.** Use of dust collection can reduce dust-related hazards.
8. **Do not let familiarity gained from frequent use of tools allow you to become complacent and ignore tool safety principles.** A careless action can cause severe injury within a fraction of a second.

Power tool use and care

1. **Do not force the power tool. Use the correct power tool for your application.** The correct power tool will do the job better and safer at the rate for which it was designed.
2. **Do not use the power tool if the switch does not turn it on and off.** Any power tool that cannot be controlled with the switch is dangerous and must be repaired.
3. **Disconnect the plug from the power source and/or remove the battery pack, if detachable, from the power tool before making any adjustments, changing accessories, or storing power tools.** Such preventive safety measures reduce the risk of starting the power tool accidentally.
4. **Store idle power tools out of the reach of children and do not allow persons unfamiliar with the power tool or these instructions to operate the power tool.** Power tools are dangerous in the hands of untrained users.
5. **Maintain power tools and accessories. Check for misalignment or binding of moving parts, breakage of parts and any other condition that may affect the power tool's operation. If damaged, have the power tool repaired before use.** Many accidents are caused by poorly maintained power tools.
6. **Keep cutting tools sharp and clean.** Properly maintained cutting tools with sharp cutting edges are less likely to bind and are easier to control.
7. **Use the power tool, accessories and tool bits etc. in accordance with these instructions, taking into account the working conditions and the work to be performed.** Use of the power tool for operations different from those intended could result in a hazardous situation.
8. **Keep handles and grasping surfaces dry, clean and free from oil and grease.** Slippery handles and grasping surfaces do not allow for safe handling and control of the tool in unexpected situations.

Service

1. **Have your power tool serviced by a qualified repair person using only identical replacement parts.** This will ensure that the safety of the power tool is maintained.

Additional Safety Warnings Safety instructions for cut-off machines

Cut-off machine safety warnings

1. **Position yourself and bystanders away from the plane of the rotating wheel.** The guard helps to protect the operator from broken wheel fragments and accidental contact with wheel.
2. **Use only bonded reinforced or diamond cut-off wheels for your power tool.** Just because an accessory can be attached to your power tool, it does not assure safe operation.
3. **The rated speed of the accessory must be at least equal to the maximum speed marked on the power tool.** Accessories running faster than their rated speed can break and fly apart.
4. **Wheels must be used only for recommended applications. Foreexample: do not grind with the side of a cut-off wheel.** Abrasive cut-off wheels are intended for peripheral grinding, side forces applied to these wheels may cause them to shatter.
5. **Always use undamaged wheel flanges that are of correct diameter for your selected wheel.** Proper wheel flanges support the wheel thus reducing the possibility of wheel breakage.
6. **The outside diameter and the thickness of your accessory must be within the capacity rating of your power tool.** Incorrectly sized accessories cannot be adequately guarded or controlled.
7. **The arbour size of wheels and flanges must properly fit the spindle of the power tool.** Wheels and flanges with arbour holes that do not match the mounting hardware of the power tool will run out of balance, vibrate excessively and may cause loss of control.
8. **Do not use damaged wheels. Before each use, inspect the wheels for chips and cracks. If the power tool or wheel is dropped, inspect for damage or install an undamaged wheel. After inspecting and installing the wheel, position yourself and bystanders away from the plane of the rotating wheel and run the power tool at maximum no load speed for one minute.** Damaged wheels will normally break apart during this test time.

9. **Wear personal protective equipment.** Depending on application, use **face shield, safety goggles or safety glasses.** As appropriate, wear **dust mask, hearing protectors, gloves and shop apron capable of stopping small abrasive or workpiece fragments.** The eye protection must be capable of stopping flying debris generated by various operations. The dust mask or respirator must be capable of filtering particles generated by your operation. Prolonged exposure to high intensity noise may cause hearing loss.
10. **Keep bystanders a safe distance away from work area. Anyone entering the work area must wear personal protective equipment.** Fragments of workpiece or of a broken wheel may fly away and cause injury beyond immediate area of operation.
11. **Position the cord clear of the spinning accessory.** If you lose control, the cord may be cut or snagged and your hand or arm may be pulled into the spinning wheel.
12. **Regularly clean the power tool's air vents.** The motor's fan can draw the dust inside the housing and excessive accumulation of powdered metal may cause electrical hazards.
13. **Do not operate the power tool near flammable materials. Do not operate the power tool while placed on a combustible surface such as wood.** Sparks could ignite these materials.
14. **Do not use accessories that require liquid coolants.** Using water or other liquid coolants may result in electrocution or shock.

Kickback and related warnings

Kickback is a sudden reaction to a pinched or snagged rotating wheel. Pinching or snagging causes rapid stalling of the rotating wheel which in turn causes the uncontrolled **cutting unit** to be forced upwards toward the operator.

For example, if an abrasive wheel is snagged or pinched by the workpiece, the edge of the wheel that is entering into the pinch point can dig into the surface of the material causing the wheel to climb out or kick out. Abrasive wheels may also break under these conditions. Kickback is the result of power tool misuse and/or incorrect operating procedures or conditions and can be avoided by taking proper precautions as given below.

1. **Maintain a firm grip on the power tool and position your body and arm to**

allow you to resist kickback forces.

The operator can control upward kickback forces, if proper precautions are taken.

2. **Do not position your body in line with the rotating wheel.** If kickback occurs, it will propel the cutting unit upwards toward the operator.
3. **Do not attach a saw chain, woodcarving blade, segmented diamond wheel with a peripheral gap greater than 10 mm or toothed saw blade.** Such blades create frequent kickback and loss of control.
4. **Do not "jam" the wheel or apply excessive pressure. Do not attempt to make an excessive depth of cut.** Overstressing the wheel increases the loading and susceptibility to twisting or binding of the wheel in the cut and the possibility of kickback or wheel breakage.
5. **When the wheel is binding or when interrupting a cut for any reason, switch off the power tool and hold the cutting unit motionless until the wheel comes to a complete stop. Never attempt to remove the wheel from the cut while the wheel is in motion otherwise kickback may occur.** Investigate and take corrective action to eliminate the cause of wheel binding.
6. **Do not restart the cutting operation in the workpiece. Let the wheel reach full speed and carefully re-enter the cut.** The wheel may bind, walk up or kickback if the power tool is restarted in the workpiece.
7. **Support any oversized workpiece to minimize the risk of wheel pinching and kickback.** Large workpieces tend to sag under their own weight. Supports must be placed under the workpiece near the line of cut and near the edge of the workpiece on both sides of the wheel.

Residual risks

Even when the power tool is used as prescribed it is not possible to eliminate all residual risk factors. The following hazards may arise in connection with the power tool's construction and design:

1. Health defects resulting from vibration emission if the power tool is being used over longer period of time or not adequately managed and properly maintained.
2. Injuries and damage to property due to broken accessories that are suddenly dashed.

Warning

This power tool produces an electromagnetic field during operation. This field may under some circumstances interfere with active or passive medical implants. To reduce the risk of serious or fatal injury, we recommend persons with medical implants to consult their physician and the medical implant manufacturer before operating this power tool.

Intended Use

The machine is intended for stationary use with cutting discs to perform lengthways and crossways straight cuts or mitre cuts to 45° in metal materials without the use of water.

Product Features

The numbering of the components shown refers to the representation of the power tool on the graphic pages.

1. On/Off switch
2. Handle
3. Blade guard (Option)
4. Spindle lock
5. Cutting disc (14")
6. Angle stop
7. Clamping spindle
8. Quick-release button
9. Spindle handle
10. Base plate
11. Locking screw for angle stop
12. Safety-lock
13. Depth stop
14. Tool arm
15. Transport handle
16. Retracting blade guard
17. Spark guard
18. Tool spindle
19. Clamping flange
20. Washer
21. Hexagon bolt
22. Lock nut of the depth stop
23. Ring spanner

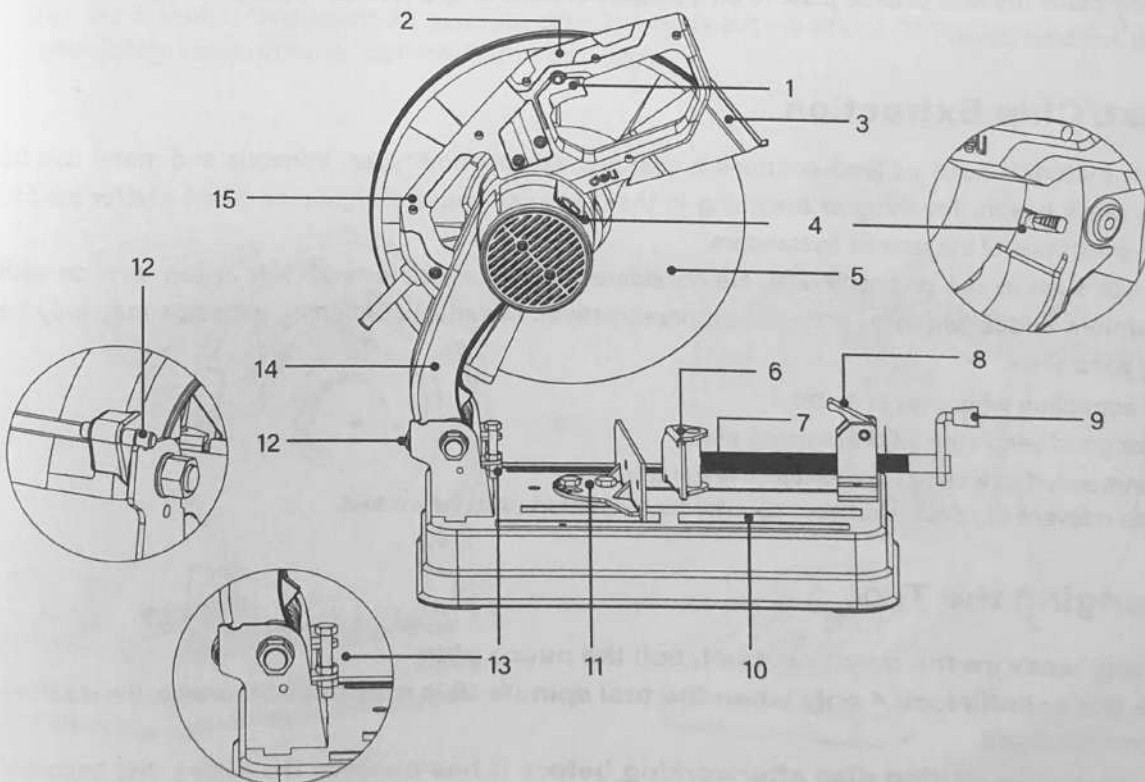
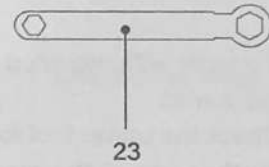
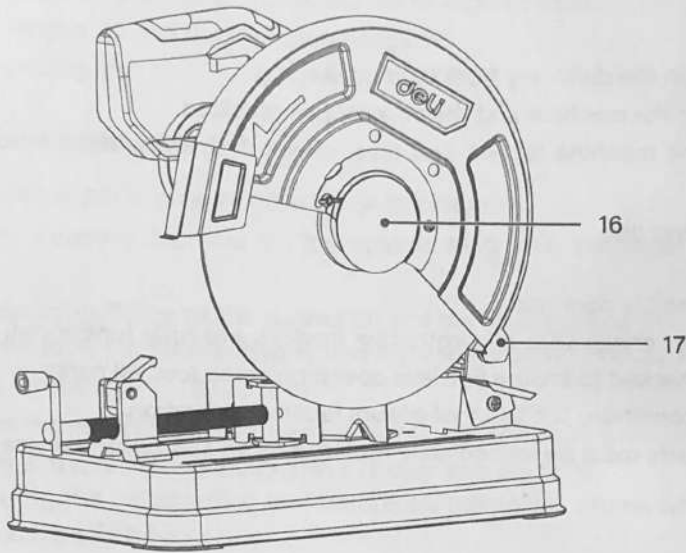

Assembly

Avoid unintentional starting of the machine. During assembly and for all work on the machine, the power plug must not be connected to the mains supply.

1 Delivery Scope

Carefully remove all parts included in the delivery from their packaging.

Remove all packaging material from the machine and the accessories provided.

Before starting the operation of the machine for the first time, check if all parts listed below have been supplied:

- Cut-off grinder with mounted cutting disc
- Ring spanner 23

Note: Check the power tool for possible damage.

Before further use of the machine, check that all protective devices are fully functional. Any lightly damaged parts must be carefully checked to ensure flawless operation of the tool. All parts must be properly mounted and all conditions fulfilled that ensure faultless operation.

Damaged protective devices and parts must be immediately replaced by an authorised service centre.

2 Flexible Mounting

In the exceptional case that it should not be possible to firmly bench-mount the power tool, you can provisionally place the legs of base plate 10 on a suitable surface (e. g. a workbench, level floor, etc.) without bolting the machine down.

3 Dust/Chip Extraction

Dusts from materials such as lead-containing coatings, some wood types, minerals and metal can be harmful to one's health. Touching or breathing-in the dusts can cause allergic reactions and/or lead to respiratory infections of the user or bystanders.

Certain dusts, such as oak or beech dust, are considered as carcinogenic, especially in connection with wood-treatment additives (chromate, wood preservative). Materials containing asbestos may only be worked by specialists.

- Use dust extraction whenever possible.
- Provide for good ventilation of the working place.
- It is recommended to wear a P2 filter-class respirator.

Observe the relevant regulations in your country for the materials to be worked.

4 Changing the Tool

- **Before any work on the machine itself, pull the mains plug.**
- **Actuate the spindle lock 4 only when the tool spindle 18 is stopped.** Otherwise, the machine can become damaged.
- **Do not touch the cutting disc after working before it has cooled.** The cutting disc becomes very hot while working.

Use only cutting discs that have an equal or higher maximal allowable speed than the no-load speed of your power tool.

Use only cutting discs that correspond to the characteristic data given in these operating instructions and are checked according to

EN 12413 and marked appropriately.

Removing the Cutting Disc

- Bring the power tool into the working position. (see "Releasing the Machine (Working Position)")
- Swing back the retracting blade guard 16 to the stop.
- Turn hexagon bolt 21 with the provided ring spanner 23 and at the same time press the spindle lock 4 until it engages.
- Hold the spindle lock pressed and unscrew the hexagon bolt 21.
- Remove the washer 20 and the clamping flange 19.
- Remove the cutting disc 5.

Installing the Cutting Disc

If required, clean all parts to be mounted prior to assembly.

- Mount the new cutting disc onto the tool spindle 18 in such a manner that its label faces away from the tool arm.
- Mount the clamping flange 19, the washer 20 and the hexagon bolt 21. Press spindle lock 4 until it engages and tighten hexagon bolt 21 with the provided ring spanner 23. (Tightening torque approx. 18–20 Nm)
- Slowly guide the retracting blade guard 16 down until the cutting disc is covered off.
- Make sure that the retracting blade guard 16 operates properly. After mounting the cutting disc and before switching on, check whether the cutting disc is properly mounted and if it can rotate freely.
- Make sure that the cutting disc does not graze against the retracting blade guard 16, the blade guard 3 or against other parts.
- Run the machine for approx. 30 seconds. Should significant vibrations occur, switch off the machine immediately; remove and install the cutting disc again.

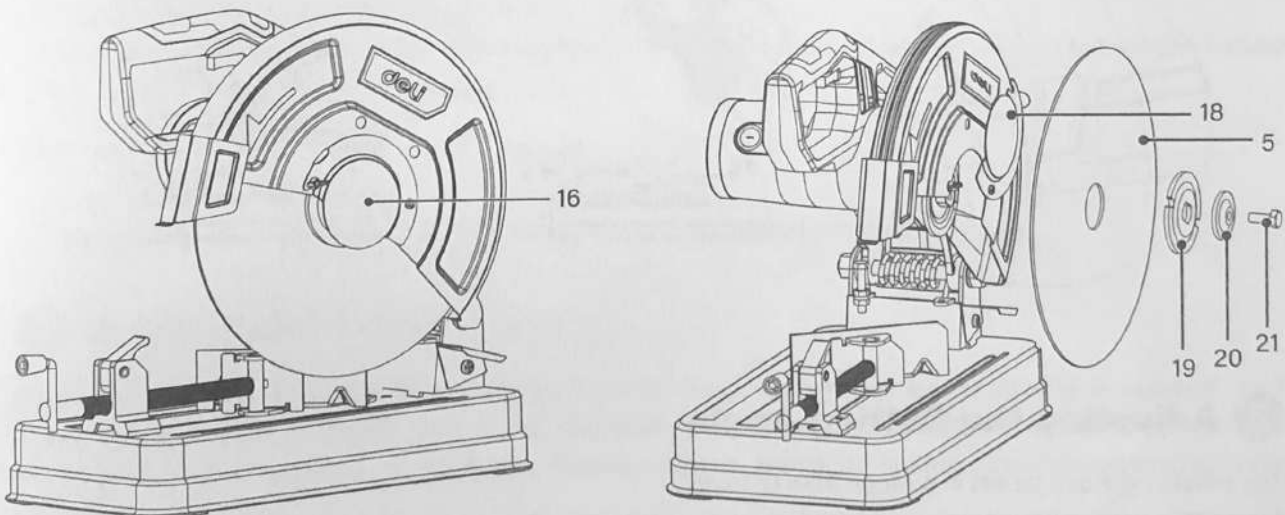

Operation

Before any work on the machine itself, pull the mains plug.

1 Safety lock

According to Figure C

Before using the machine:

Make sure the safety-lock is opening, and then push the tool arm upward.

After using the machine:

Pull the Plug first, and then close the safety-lock and push the tool arm downward.

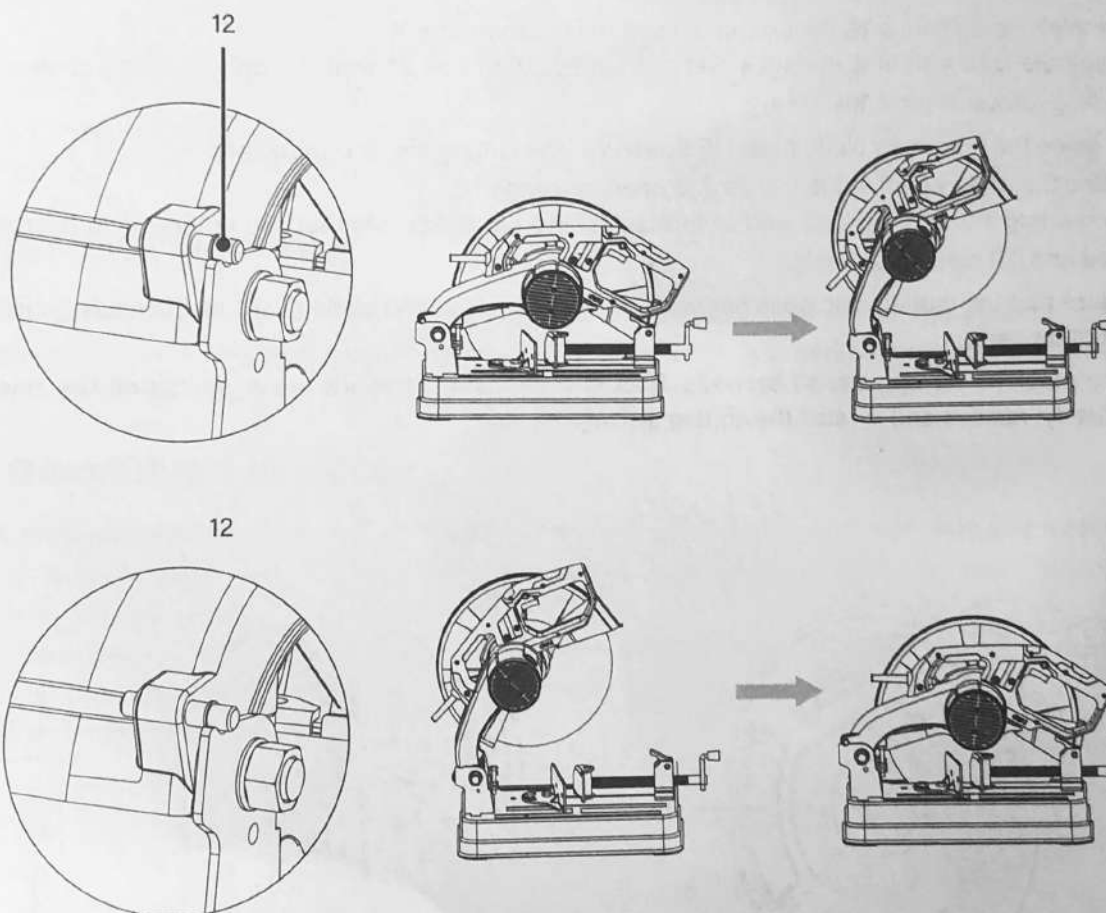

2 Adjusting the Cutting Angle

The miter angle can be set in a range from 0° to 45°.

Frequently used mitre angles are identified on the angle stop 6 with appropriate markings. The 0° and 45° position are set at the respective end stop.

- Loosen the locking screws 11 for the angle stop with the supplied ring spanner 23
- Adjust the desired angle and firmly tighten both locking screws 11 again.

Displacing the Angle Stop (see figure D and E)

When cutting workpieces wider than 140 mm, the angle stop 6 can be displaced to the rear.

- Completely unscrew locking screws 11 with the supplied ring spanner 23.
- Move the angle stop 7 toward the rear by one or two holes to the desired clearance.
- Adjust the desired angle and firmly tighten both locking screws 11 again.

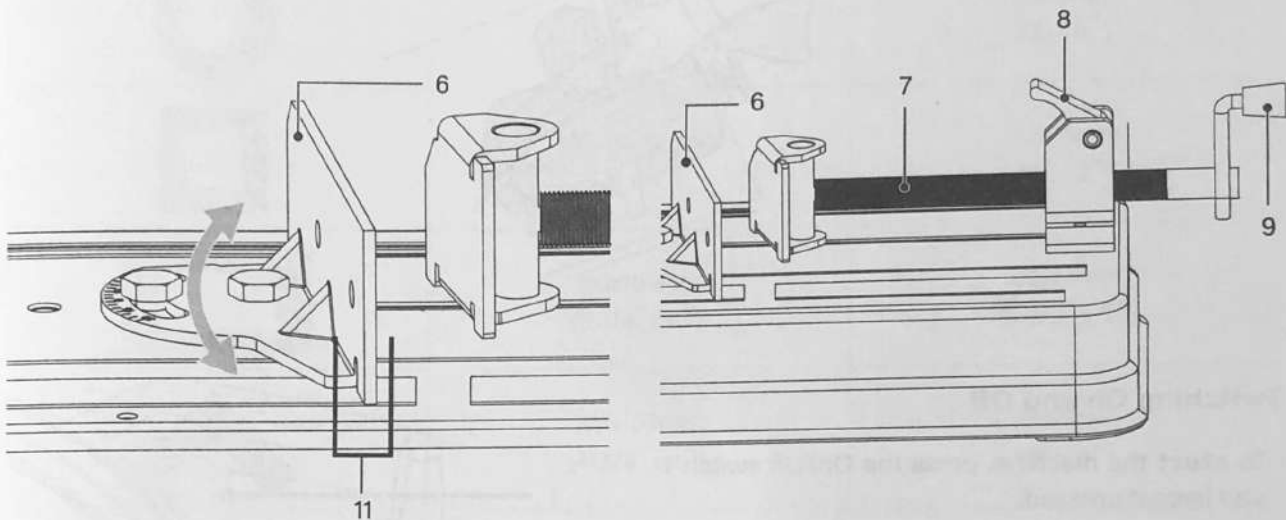

3 Clamping the Workpiece

To ensure optimum working safety, the workpiece must always be firmly clamped.

Do not saw workpieces that are too small to clamp.

Long workpieces must be underlaid or supported at their free end.

- Place the workpiece against the angle stop 6.
- Slide the clamping spindle 7 against the workpiece and firmly clamp the workpiece with the spindle handle 9.

Loosening the Workpiece

- Loosen the spindle handle 9.
- Tilt up the quick release 8 and pull the clamping spindle 7 away from the workpiece.

4 Starting Operation

Check the cutting disc before using. The cutting disc must be properly mounted and must rotate freely. Carry out a 30 second (min.) test run with no load. Do not use damaged, out-of-centre or vibrating cutting discs. Damaged cutting discs can burst and cause injuries.

User Position

Do not stand in a line with the cutting disc in front of the machine. Always stand aside of the cutting disc. This measure provides for better protection of your body against possible splinters in case of cutting disc breakage.

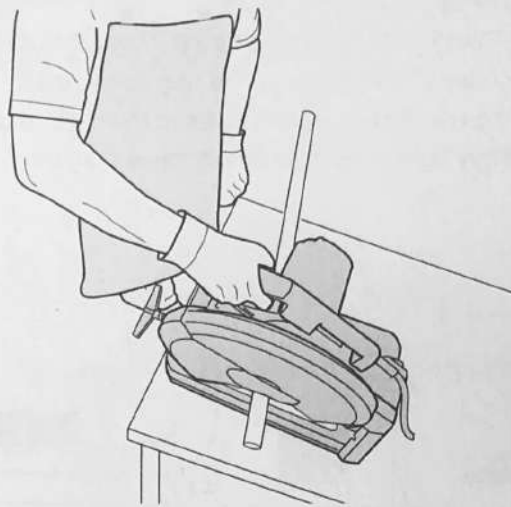

Switching On and Off

- To **start** the machine, press the On/Off switch 1 and keep it pressed.

Note: For safety reasons, the On/Off switch 1 cannot be locked; it must remain pressed during the entire operation.

- To **switch off** the machine, release the On/Off switch 1.

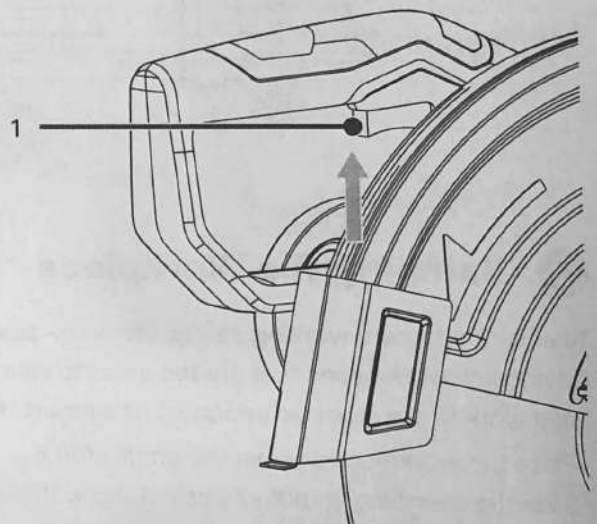

5 Working Advice



- **Before any work on the machine itself, pull the mains plug.**

General Cutting Instructions

- **Do not touch the cutting disc after working before it has cooled.** The cutting disc becomes very hot while working.
- **Make sure that the spark guard 17 is properly mounted.** Sparking occurs when cutting metal. Protect the cutting disc against impact, shock and grease. Do not subject the cutting disc to lateral pressure. Do not strain the power tool so heavily that it comes to a standstill. Excessive feed considerably reduces the performance capability of the machine and shortens the service life of the cutting disc. Use only cutting discs that are suitable for the material to be worked.

Permissible Workpiece Dimensions

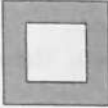
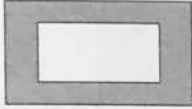
Maximal workpiece sizes:

Workpiece Form	Mitre/Bevel Angle	
	0°	45°
	Ø100 (4")	Ø100 (3-1/8")
	100x100mm (4" x 4")	75x75mm (3" x 3")
	160x100mm (6-1/4" x 4")	80x75mm (3-1/8" x 3")
	120x100mm (4-3/4" x 4")	75x75mm (3" x 3")

Minimal workpiece sizes

(= all workpieces that can be clamped via the clamping spindle 7): Length 80 mm

Adjusting the Depth Stop (see figure H)

In the delivery condition of the machine, the depth stop 13 is adjusted in such a manner that a new 355 mm cutting disc does not touch the base plate when cutting.

To compensate the wear of the cutting disc, the depth stop can be set deeper.

When using a new cutting disc, the depth stop must then always be set back to the original position.

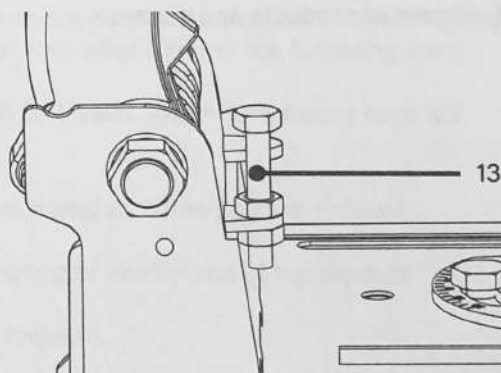

Always adjust the depth stop in such a manner that the cutting disc does not touch the base plate when cutting.

- Bring the power tool into the working position. (see "Releasing the Machine (Working Position)")
 - Loosen lock nut 22.
 - Swing the tool arm with the handle 2 to the requested position.
 - Screw the depth stop 13.
 - Slowly guide the tool arm upward and tighten the lock nut 22 .
- Transport

- Always carry the power tool by its transport handle 15 .

The power tool should always be carried by two persons in order to avoid back injuries. When transporting the power tool, use only the transport devices and never use the protective devices.

Maintenance and Service

1 Maintenance and Cleaning

Before any work on the machine itself, pull the mains plug.

For safe and proper working, always keep the machine and ventilation slots clean.

In extreme conditions, always use dust extraction as far as possible. Blow out ventilation slots frequently and install a residual current device (RCD). When working metals, conductive dust can settle in the interior of the power tool. The total insulation of the power tool can be impaired.

Have maintenance and repair work performed only by qualified specialists. In this manner, it can be ensured that the safety of the power tool is maintained.

The retracting blade guard must always be able to move freely and retract automatically. Therefore, always keep the area around the retracting blade guard clean.

2 Accessories

Cutting disc (355mm 14") Wrench
Carbon brushes

3 After-sales Service and Customer Assistance

Our after-sales service responds to your questions concerning maintenance and repair of your product as well as spare parts.

Our customer service representatives can answer your questions concerning possible applications and adjustment of products and accessories.